



AW7500PRO

Lithium Battery

USER MANUAL

About This Manual

Purpose

This manual describes the assembly, installation, operation, maintenance, and troubleshooting of the AW7500PRO Lithium Battery unit. Ensure you read this manual carefully before installation and operation.

Scope

This manual provides safety and installation instructions as well as information on tools, wiring, commissioning, and routine maintenance for the AW7500PRO battery system.





Target Group

This document is intended for trained and qualified individuals. Procedures that do not require specific electrical qualifications may be performed by end-users only when explicitly stated. A qualified person must have:

- Relevant know-how and experience in the operation and installation of lithium batteries and electrical devices (in particular inverters).
- Knowledge of the applicable standards and safety procedures related to such installations.
- The ability to recognize and avoid dangers.
- Training on this specific AW7500PRO product or similar LiFePO₄ battery.

Symbol Definitions

The following symbols may be used in this manual or on the product. It is crucial to understand their meaning to ensure safe installation and operation.

 DANGER:	Indicates a hazardous situation which, if not avoided, will result in death or serious injury.
 WARNING:	Indicates a hazardous situation which, if not avoided, could result in death or serious injury.
 CAUTION:	Indicates a hazardous situation which, if not avoided, could result in minor or moderate injury or equipment damage.
 NOTICE:	Indicates practices not related to personal injury but important for correct operation or to avoid equipment damage.
NOTE:	Provides additional information or tips.

Abbreviations

- **BMS:** Battery Management System
- **SOC:** State of Charge
- **DOD:** Depth of Discharge
- **PPE:** Personal Protective Equipment
- **SELV:** Safety Extra Low Voltage
- **LFP:** Lithium Iron Phosphate (LiFePO₄)
- **CC/CV/CP:** Constant Current / Constant Voltage / Constant Power
- **RH:** Relative Humidity

- **ADDR:** Address (for DIP Switch)
- **CAN:** Controller Area Network
- **RS485:** Recommended Standard 485 (Serial Communication)
- **RS232:** Recommended Standard 232 (Serial Communication)

DISCLAIMER

Before using this product, please carefully read this manual, especially safety instructions, warning information, terms of use, and disclaimers. Users are solely responsible for any losses caused by their failure to use this product in accordance with this user manual. In compliance with laws and regulations, the final interpretation rights of this document and all related documents of this product belong to the company. No further notifications will be given in case of any update, revision, or termination.

This document is subject to revision and may be updated without prior notice. While the AW7500PRO Lithium Battery utilizes advanced Lithium Iron Phosphate (LiFePO₄) chemistry, recognized for its enhanced safety characteristics compared to other lithium-ion technologies, and incorporates a sophisticated Battery Management System (BMS) for protection, all lithium battery systems inherently store significant electrical energy and carry potential risks if mishandled.

The information, guidelines, and suggestions provided in this manual are intended for professional installers and qualified users. The manufacturer assumes no responsibility for any damages, injuries, or losses arising from:

- Failure to strictly adhere to the instructions and safety precautions detailed in this manual.
- Unauthorized modifications, alterations, or repairs to the product. * Improper installation, commissioning, operation, or maintenance.
- Non-compliance with local electrical codes, building regulations, or industry standards.
- Use of the product outside its specified operating parameters, environmental conditions, or intended applications.
- Damage caused by external factors including, but not limited to, natural disasters, power surges, or incorrect integration with incompatible equipment.

Adherence to this manual and all applicable regulations is critical for safe and reliable operation.

TABLE OF CONTENT

1. Safety Instructions.....	5
1.1 General Safety Precautions.....	5
1.2 Electrical Safety	5
1.3 Handling and Installation Safety.....	6
1.4 Storage Safety	6
1.5 Emergency Procedures.....	7
1.6 Battery Disposal.....	8
2. Product Overview	8
2.1 Brief Introduction	8
2.2 Product Features.....	8
2.3 Product Appearance.....	8
2.4 Technical Specifications.....	9
2.4.1 General Parameters	9
2.4.2 Dimensions and Weight	9
2.5 Interface Description.....	10
2.5.1 Front Panel Overview	10
2.5.2 Communication Port Pinouts (RS232, RS485, CAN)	10
2.5.3 DIP Switch Configuration (ADDR).....	11
2.6 Battery Management System (BMS).....	13
2.6.1 Voltage Protection	13
2.6.2 Current Protection	13
2.6.3 Temperature Protection	13
2.6.4 Other Protections	13
3. Installation	14
3.1 Pre-Installation Checks	14
3.1.1 Safety Requirements.....	14
3.1.2 Required Tools and Equipment	14
3.1.3 Safety Gear.....	15
3.1.4 Unpacking and Inspection	15
3.1.5 Packing List	15
3.2 Installation Environment.....	16
3.2.1 Environmental Requirements	16
3.2.2 Installation Location Precautions	17
3.2.3 Installation Spacing.....	17
3.3 Mechanical Installation	17
3.3.1 Mounting the Battery (Wall Mount)	17
3.3.2 Parallel Installation (Physical Arrangement)	19
3.4 Electrical Installation.....	20
3.4.1 Grounding	21

3.4.2 Cable Overview and Preparation	21
3.4.3 Connecting Batteries in Parallel (Power to Busbar)	23
3.4.4 Connecting Batteries in Parallel (Inter-Battery Communication)	21
3.4.5 Connecting to the Inverter (Power and Communication)	Error! Bookmark not defined.
3.4.6 Circuit Breaker Installation	24
3.5 System Configuration	25
3.5.1 DIP Switch Settings for Parallel Operation	24
3.5.2 Communication Setup with Inverter	25
4. Commissioning	25
4.1 Pre-Power-On Checklist	25
4.2 Initial Startup Procedure	26
4.2.1 Powering on the Battery System.....	26
4.2.2 Verifying LED Indicators	26
4.2.3 Voltage Checks.....	26
4.3 Inverter Integration and System Test.....	27
5. Operation.....	27
5.1 Normal Operation	27
5.2 LED Indicator Status.....	27
5.3 Shutting Down the System	28
6. Maintenance	28
6.1 Routine Maintenance Schedule	28
6.2 Cleaning	29
6.3 Cable and Connection Checks.....	29
6.4 Battery Health and SOC Management	29
7. Storage	29
7.1 Short-Term Storage (Up to 3 months).....	29
7.2 Long-Term Storage (More than 3 months)	30
8. Decommissioning and Disposal	30
8.1 Safe Decommissioning.....	30
8.2 Battery Disposal.....	30
9. Appendix.....	31
9.1 Compatible Inverter List	31

1. SAFETY INSTRUCTIONS

DANGER

HIGH ENERGY HAZARD: Lithium batteries store a large amount of electrical energy. Failure to follow safety instructions can lead to severe electric shock, fire, explosion, or release of hazardous substances, resulting in death or serious injury.

AUTHORIZED PERSONNEL ONLY: Only qualified, trained, and authorized personnel are permitted to install, operate, maintain, or service the AW7500PRO battery system. Internal maintenance is only to be carried out by an authorized personnel from the manufacturer or certified service provider.

NO USER-SERVICEABLE PARTS INSIDE: Never attempt to disassemble, modify, open, or repair the battery unit. The battery contains no user-serviceable parts. Any attempt to do so will void the warranty and can lead to catastrophic failure. Contact authorized service personnel for any issues.

DE-ENERGIZE BEFORE WORK: Always ensure the battery system is completely powered off and de-energized, and disconnected from all external electrical sources (inverter, grid, PV, other batteries) before performing any installation, wiring, maintenance, or cleaning. Verify de-energization with a calibrated multimeter at all relevant connection points. Implement Lockout/Tagout (LOTO) procedures.

1.1 GENERAL SAFETY PRECAUTIONS

Read and Understand: Before using the AW7500PRO battery, thoroughly read and understand all safety instructions, warnings, and procedures in this manual. If any part is unclear, seek clarification from your supplier or a qualified expert before proceeding.

Qualified Personnel: Installation, maintenance, and repair must be performed by qualified, certified, and authorized personnel only, who are familiar with LiFePO₄ battery systems and their associated risks.

Fire Safety:

- Keep a Class D fire extinguisher (for metal fires) and an ABC or CO₂ fire extinguisher (suitable for electrical fires) readily accessible.
- **NEVER use water to extinguish a battery fire**, as it can exacerbate the situation with lithium batteries.
- Familiarize yourself with the appropriate fire response for lithium battery incidents.

No Smoking or Open Flames: Strictly prohibit smoking, sparks, open flames, or any ignition sources in the vicinity of the battery system and during installation or maintenance.

Ventilation: Ensure adequate ventilation around the battery to prevent the accumulation of heat and potentially flammable gases (though LFP batteries are generally safer in this regard, good ventilation practice remains essential for thermal management and dispersing any off-gassing in fault conditions).

Chemical Hazard: Although LiFePO₄ is a safer lithium chemistry, damaged cells can leak electrolyte. Avoid contact with skin or eyes. Refer to Emergency Procedures (Section 1.5).

1.2 ELECTRICAL SAFETY

WARNING

LETHAL VOLTAGES: The battery system operates at voltages that can be lethal. Exercise extreme caution and adhere to all electrical safety procedures.

Power Off Verification: Before commencing any work, ensure the battery system is completely powered off. Disconnect it from all AC and DC power sources, including the inverter, PV array, grid, and any paralleled batteries. Use a multimeter to verify zero energy state at terminals and cables.

Short Circuit Prevention:

- **CRITICAL RISK:** Short-circuiting battery terminals or connected live parts can cause extremely high currents, leading to arcing, fire, explosion, and severe burns.
- Do not allow tools, jewelry (rings, watches, necklaces), or other conductive materials to come into contact with battery terminals or busbars simultaneously. Remove all metallic personal items before working on or near the battery.
- Use properly insulated tools specifically rated for electrical work.

Insulation and PPE: Always use properly insulated tools. Wear appropriate Personal Protective Equipment (PPE), including but not limited to:

- Voltage-rated rubber gloves (Class 0 or higher, appropriate for system voltage).
- Safety glasses with side shields or a full-face shield.
- Safety shoes (electrically insulated).
- Flame-resistant (FR) clothing, if available or required by local regulations.

Correct Polarity: Ensure correct polarity when connecting battery cables. Incorrect polarity **will** damage the battery, the inverter, and other connected equipment, and can create a fire or explosion hazard. Double-check all connections before energizing.

Work Alone Prohibition: Never work alone on energized or potentially energized high-voltage equipment. Ensure a second person, trained in emergency shutdown and rescue, is present.

1.3 HANDLING AND INSTALLATION SAFETY

! CAUTION

Weight Hazard: The AW7500PRO battery unit is heavy (approximately 49.5kg). Use appropriate lifting techniques, mechanical aids (e.g., lifting straps, dolly), or assistance from at least two persons to prevent musculoskeletal injury and damage to the unit.

Physical Damage:

- Handle batteries with extreme care. Avoid dropping, crushing, puncturing, denting, or applying excessive force, as this can cause internal damage, short circuits, and potential safety hazards (thermal runaway, fire).
- Inspect the battery unit thoroughly for any signs of physical damage (cracks, dents, deformation, leaking fluids) before installation.
- **Do not install or use a damaged battery.** Immediately quarantine a damaged battery in a safe, isolated area and contact your supplier.

Secure Mounting: Ensure the battery is securely mounted according to the installation instructions on a stable, robust surface capable of supporting its weight. This prevents it from falling, tipping over, or being subjected to excessive vibration, which could lead to damage or disconnection.

Tripping Hazards: Keep the installation area clear and manage cables effectively to prevent tripping hazards.

1.4 STORAGE SAFETY

NOTICE

Storage Temperature: Store the battery in a dry, cool, well-ventilated indoor place, away from direct sunlight, heat sources, and corrosive substances.

- Recommended storage temperature: -20°C to +45°C (-4°F to +113°F).
- For extended storage (over one year): -20°C to +25°C (-4°F to +77°F) is optimal.

- **Avoid extreme temperatures outside the specified range as this can permanently degrade battery performance and lifespan.**

Charge State for Storage:

- For short-term storage (up to 3 months): Store with SOC between 40% and 60%.
- For long-term storage (more than 3 months): Charge the battery to approximately 60%~80% SOC before storing.

Recharge During Storage: To prevent irreversible capacity loss due to self-discharge and to maintain battery health, recharge the battery to 60%~80% SOC at least every six months during extended storage. Document recharge dates. **Failure to do so may void the warranty.**

Avoid Water Exposure: Do not expose the battery to water, moisture, condensation, or high humidity environments during storage.

Preventive Measures: Ensure that the battery is stored away from flammable materials, corrosive substances, and heat sources. Do not stack heavy objects on the battery.

Original Packaging: If possible, store the battery in its original packaging to provide protection.

1.5 EMERGENCY PROCEDURES

Electrolyte Leakage: LiFePO₄ electrolyte is less hazardous than other lithium chemistries, but caution is still essential.

- In the rare event of electrolyte leakage (e.g., from a physically damaged cell), avoid all contact with the leaking substance (skin, eyes, inhalation).
- **Skin Contact:** Immediately rinse the affected area with copious amounts of clean water for at least 15 minutes. Remove contaminated clothing. Seek medical attention if irritation persists.
- **Eye Contact:** Immediately flush eyes with clean water or an eyewash solution for at least 15 minutes, holding eyelids open. Seek immediate medical attention.
- **Inhalation:** If fumes or electrolyte mist is inhaled, move to an area with fresh air immediately. Seek medical attention if respiratory irritation or difficulty breathing occurs.
- **[Added] Ingestion:** Do not induce vomiting. Rinse mouth with water. Seek immediate medical attention.

Damaged Batteries:

- **Do not attempt to use, charge, move (unless for immediate safety), or repair damaged batteries.**
- If a battery shows signs of damage (swelling, leaking, unusual odor, deformation), immediately isolate the area.
- If safe to do so, power down and disconnect the damaged battery.
- Contact the manufacturer, supplier, or qualified hazardous materials team for guidance on handling and disposal.

Fire Response: In the event of a battery fire:

1. **Evacuate the area immediately.** Prioritize human safety.
2. **Contact emergency services** (e.g., fire department) and inform them it is a lithium battery fire.
3. **If safe to do so and you are trained:**
 - Use a Class D fire extinguisher (for lithium-ion battery fires if specified) or a large ABC dry chemical extinguisher or CO₂ extinguisher.
 - **DO NOT USE WATER, FOAM, OR SAND.** Water can react with lithium and worsen the fire or cause explosions.
4. If possible and safe, disconnect all power to the battery system (external breakers, switches) to prevent further energy input.

5. **Ventilate the area** (after the fire is extinguished) to clear smoke and potential toxic fumes, but only if safe to re-enter.

1.6 BATTERY DISPOSAL

NOTICE

ENVIRONMENTAL RESPONSIBILITY: Lithium batteries contain materials that can be harmful to the environment if not disposed of correctly.

Do not dispose of batteries with household or general municipal waste.

The storage, use, and disposal of the products shall be carried out in strict accordance with the product manual, relevant contract, or applicable local, national, and international environmental laws and regulations for lithium battery recycling.

Contact your local authorities, the battery supplier, or an authorized battery recycling facility for proper disposal and recycling procedures. LiFePO₄ batteries require specific recycling processes.

Keep records of disposal.

2. PRODUCT OVERVIEW

2.1 BRIEF INTRODUCTION

The AW7500PRO Lithium Batteries are advanced energy storage devices utilizing Lithium Iron Phosphate (LiFePO₄) cell technology. They are designed for use in backup power solutions, solar energy storage systems, and other applications requiring reliable and long-lasting energy storage. The system can be expanded by connecting multiple units in parallel.

2.2 PRODUCT FEATURES

High Performance: Offers a significant discharge current capability

- Max. Discharge Current 150A, Peak Discharge Current 350A (100ms). Max Charge Current 75A.

Extended Lifecycle: Manufactured with high-quality LiFePO₄ cylinder cells.

Advanced BMS: Integrated Battery Management System (BMS) provides comprehensive protection against charge/discharge over current, high/low temperatures, while also managing cell balancing for optimal performance.

Environmentally Friendly: Complies with European RoHS standards, SGS Certified, and composed of non-toxic materials.

Scalability: Parallelable up to 15 units for increased energy storage capacity.

High Depth of Discharge (DOD): High DOD and low cut-off voltage of the battery can achieve maximum usage

Communication: Supports RS232, RS485, and CAN communication protocols for monitoring and control with compatible inverters.

2.3 PRODUCT APPEARANCE

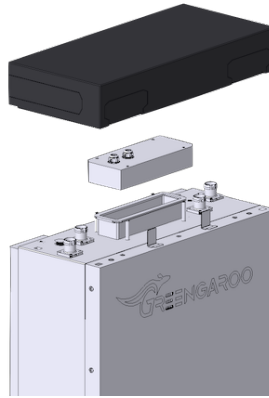

2.4 TECHNICAL SPECIFICATIONS

2.4.1 GENERAL PARAMETERS

Parameter	Value
Model	AW7500PRO
Rated Power	7500W
Parallel Capability	Up to 15 units
Rated Voltage	51.2V DC
Nominal Capacity (Energy)	4945Wh
Dimension W x D x H	665*406*195.4mm
Net Weight	About 49.5kg
Communication Interface	RS232 / RS485 / CAN
Charge Mode	CC/CV/CP
Max. Charge Current ¹⁾	75A
Charge Cut-off Voltage	57V
Discharge Mode	CC/CP
Discharge Cut-off Voltage	45V
Max. Discharge Current ²⁾	150A
Peak Discharge Current ³⁾	350A (100ms)
Humidity	5% to 95% RH (non-condensing)
Shipment Status	Voltage: 52V~54V; SOC: 60%~80%
Operating Temperature	Charging : -10~+50°C / Discharging : -20~+65°C
Storage Temperature	-20~+45°C(three months) / -20~+25°C (one year)
Warranty	10 years, > 6000 cycles life
IP Rating	IP65

Notes:

- 1) For better battery life cycles, we suggest charge in 48A(0.5C @25 ° C)
- 2) For better battery life cycles, we suggest discharge in 48A(0.5C @25 ° C)
- 3) Peak Current excludes repeated short duration (less than 100ms) of current pattern.

2.4.2 DIMENSIONS AND WEIGHT

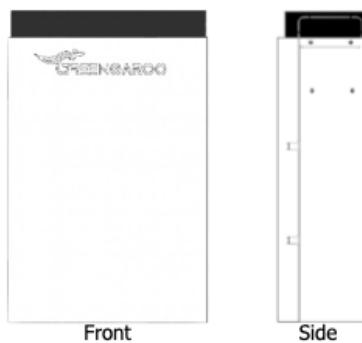

- **Dimensions (W x H x D):** ~406mm x 665mm x 195.4mm
- **Net Weight:** ~49.5kg

2.5 INTERFACE DESCRIPTION

2.5.1 FRONT PANEL OVERVIEW

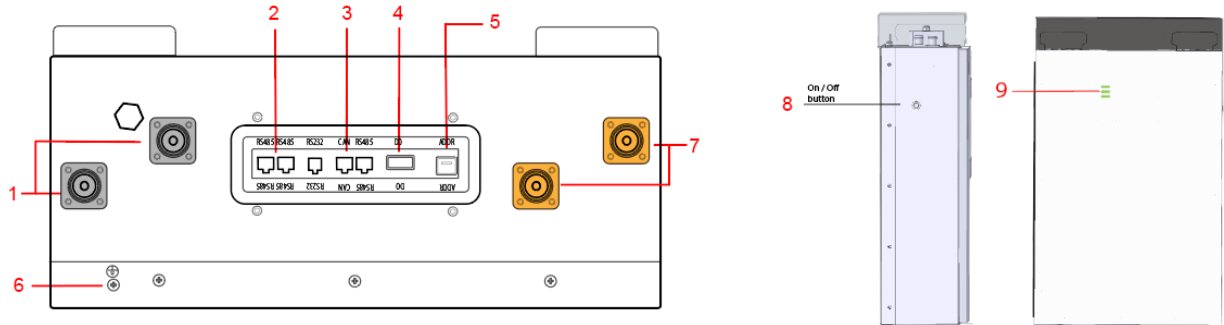

Item	Name	Definition
1	Negative Terminal	Battery power output negative or parallel connection negative line.
2	RS485 Battery Ports	Communication ports for parallel batteries
3	CAN / RS485 Port	CAN or RS485 communication port for communication with the inverter.
4	DO (Dry Contact)	Dry Contact output for signaling external devices (e.g., fault, low battery).
5	ADDR (DIP Switch)	4-bit DIP switch for setting a unique address for each battery unit.
6	Ground Terminal	Grounding connection point.
7	Positive Terminal	Battery power output positive or parallel connection positive line.
8	Power Switch (ON/OFF)	Main power switch for the battery unit
9	LED Indicators	SOC indicators (See Section 5.2 for details).

2.5.2 Communication Port Pinouts (RS232, RS485, CAN)

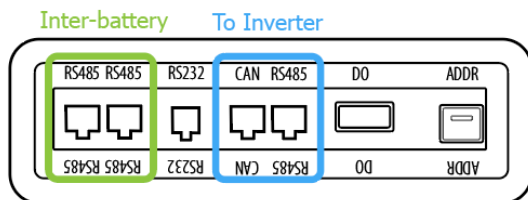

Battery - Inverter (CAN) communication port

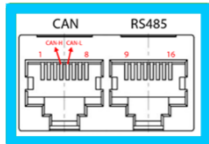

RJ45 plug in 8P8C stand type

Pin (CAN)	Description	Pin (RS485)	Description
4	CANH	11 \ 14	GND
5	CANL	10 \ 15	RS485-A1
7	GND	12 \ 13	NC
1 \ 2 \ 3 \ 6 \ 8	NC	9 \ 16	RS485-B1

Inter-battery (RS485) communication ports

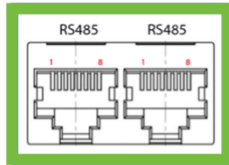

2 x RJ45 plug in 8P8C stand type

Pin (RS485)	Description
1、2、3、6、8	NC
5	CANL
4	CANH
7	GND

Dry Contact

Pin	Description
1 to 2	Normally closed. The circuit opens in the event of a battery fault or protection activation.
3 to 4	Normally closed. The circuit opens when a low battery warning is triggered.

RS232

Pin	Description
1, 2, 6	NC
3	TX
4	RX
5	GND

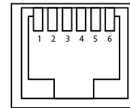

2.5.3 DIP SWITCH CONFIGURATION (ADDR)

Each battery module must have a unique address. The address is set using the 4-bit DIP switch (Item 6).

For a Single Battery System (Standalone Unit):

- If you are installing only **one** AW7500PRO battery unit that connects directly to the inverter (not in parallel with other batteries), its address **must be set to 1**. This identifies it as the primary (and only) battery communicating with the inverter.







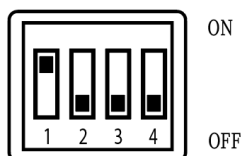

For a Parallel Battery System (Multiple Units):

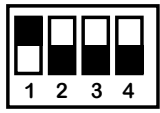
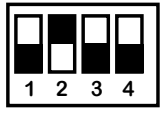
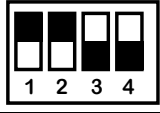
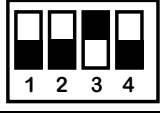
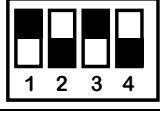
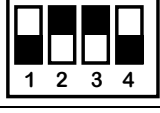
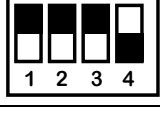
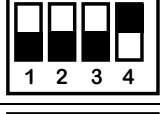
When connecting multiple battery units in parallel (up to 15 units):

- One unit **must** be designated as the **Master battery**. The Master battery's address **must be set to 1**. This unit communicates directly with the inverter and coordinates the other (slave) batteries.
- All other batteries in the parallel string are **Slave batteries**. Each Slave battery **must** have a unique address from 2 to 15.
- Refer to the table below for setting these addresses.

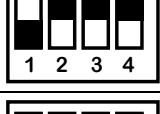

Address	ADS (Dip switch)

Master	
2	
3	
4	
5	
6	
7	
8	
9	
10	
11	
12	
13	
14	
15	

NOTICE:

SINGLE BATTERY CONFIGURATION: For a system with only one battery unit, ensure its address is set to 1.

PARALLEL SYSTEM - MASTER BATTERY: In any parallel battery system, one battery unit **MUST** be configured with Address 1 to function as the Master battery.

PARALLEL SYSTEM - UNIQUE SLAVE ADDRESSES: In a parallel system, all slave batteries must have unique addresses (from 2 to 15). Duplicate addresses will cause communication failures and system malfunction.

A maximum of 15 batteries in total (1 Master + 14 Slaves) are supported in a parallel configuration.

Incorrect DIP switch settings are a common cause of communication failures, inability for the inverter to recognize batteries, or overall system malfunction. Always verify settings before powering on.

Power off the battery unit before changing DIP switch settings to ensure the new address is correctly registered by the BMS upon startup.

2.6 BATTERY MANAGEMENT SYSTEM (BMS)

The integrated BMS provides critical protection and management functions:

2.6.1 VOLTAGE PROTECTION

- **Over-Voltage Protection (Charging):** The battery will stop charging when the cell or pack voltage reaches the maximum cut-off value. Charging will resume once the voltage drops below a predefined recovery value.
- **Under-Voltage Protection (Discharging):** The battery will disconnect the output when the cell or pack voltage drops to the minimum cut-off value. It will recover once it is recharged to a predefined recovery voltage.

2.6.2 CURRENT PROTECTION

- **Over-Current Protection (Charging):** The battery will stop charging if the charging current exceeds the maximum allowed value. Protection is typically released after a delay or when the condition is rectified.
- **Over-Current Protection (Discharging):** The battery will stop discharging if the discharge current exceeds the maximum allowed value (continuous or peak). Protection is typically released after a rated delay time or when the load is reduced.

2.6.3 TEMPERATURE PROTECTION

- **Over-Temperature Protection (Charging/Discharging):** If the internal temperature of the battery exceeds the safe operating range (e.g., $-10^{\circ}\text{C} \sim +50^{\circ}\text{C}$ during charging, $-20^{\circ}\text{C} \sim +65^{\circ}\text{C}$ during discharging), protection will be triggered, and the battery will stop charging or discharging. It will resume operation once the temperature returns to the allowed range.
- **Under-Temperature Protection (Charging/Discharging):** Similarly, if the temperature falls below the safe operating range, the battery will be protected.

2.6.4 OTHER PROTECTIONS

- **Short Circuit Protection:** In the event of an external short circuit, the BMS will trigger protection, typically by opening the discharge path. Protection may be released after removing the load/short circuit and potentially after a delay or a reset/recharge signal.

- **Dormancy/Sleep Mode:** The device may enter a low-power dormant state automatically if there are no external loads, no charging source, and no external communication for an extended to conserve energy.

NOTICE:

While the BMS provides comprehensive protection, it is designed to mitigate risks under normal operating conditions and is not a substitute for proper installation, adherence to operating limits, or regular maintenance. The BMS may not prevent all failures under extreme misuse, unauthorized modifications, or conditions beyond its design parameters.

3. INSTALLATION

⚠ DANGER

- Installation must only be performed by qualified personnel familiar with lithium battery systems and associated electrical hazards.
- Ensure all power sources (grid, PV, existing batteries, inverter) are completely de-energized and locked out before starting installation.
- Failure to follow proper installation procedures can result in equipment damage, fire, electric shock, or serious injury.

3.1 PRE-INSTALLATION CHECKS

3.1.1 SAFETY REQUIREMENTS





- The installation area must comply with all local safety regulations and building codes.
- All circuits connected to this power system with an external voltage of less than 48V (control circuits) must meet SELV requirements (e.g., as defined in IEC60950).
- Only use inverters and other equipment that are explicitly compatible with the AW7500PRO LiFePO₄ battery system (48V nominal, supporting the required communication protocol if used).
- Ensure all cabling is appropriately sized for the maximum expected current and protected against physical damage.
- Sufficient space must be available for the batteries, including clearances for ventilation and access.





The installer is solely responsible for ensuring the entire system design, component selection, and installation methods comply with all applicable local, national, and international electrical codes, safety standards, and building regulations. Failure to do so will void the product warranty and may result in severe hazards.

3.1.2 REQUIRED TOOLS AND EQUIPMENT

Tools

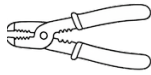
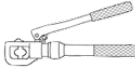
The following tools are required to install the battery pack:

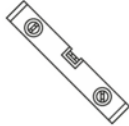
			
Crimping tool	Marker	Philips insulated screwdriver	Rubber mallet

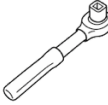
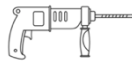
			
Wire stripper	Hydraulic crimping tool	Tape measure	Spirit level
			
Heat Gun	Insulated socket wrench	Insulated Torque socket wrench	Drilling machine

3.1.3 SAFETY GEAR

! CAUTION:

Use properly insulated tools to prevent accidental electric shock or short circuits.

		
Insulated gloves	Safety goggles	Safety shoes





3.1.4 UNPACKING AND INSPECTION

1. When the equipment arrives at the installation site, loading and unloading should be carried out according to rules and regulations, to prevent exposure to direct sunlight and rain.
2. Before unpacking, verify the total number of packages against the shipping list. Check boxes for any signs of external damage.
3. Handle all items with care during unpacking to protect surface coatings and prevent damage.
4. After opening the packaging:
 - o Carefully read all technical documentation provided.
 - o Verify all items against the packing list (see Section 3.1.5) to ensure everything is present and undamaged.
 - o Inspect the battery unit for any signs of physical damage (dents, cracks, leaking). **DO NOT install damaged batteries.**
 - o If any items are missing or damaged, or if internal packaging is compromised, document it (take photos) and contact your supplier immediately.



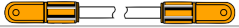

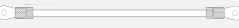

3.1.5 PACKING LIST

A. AW7500PRO Battery module package (Per Module)







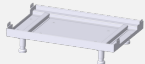

No.	Item	Q'ty (pcs)	Note
A1		1	AW7500PRO Battery Module

A2		1	Positive Power cable (Orange), 35mm ² , 1000mm length.
A3		1	Negative Power Cable (Black), 35mm ² , 1000mm length
A4		1	1 meter length (RJ45 8P8C connectors
A5		1	Ground wire Yellow-Green, 1000mm length, with OT-6 terminals on both ends.
A6		1	RJ45 header

B. AW7500PRO-WM Wall Mount (Includes 2 AW7500PRO tool sets)

No.	Item	Q'ty (pcs)	Note
B1		2	Mounting Bracket
B2		2	Wall mount template
B3		8	M8 x 80mm Expansion bolt
B4		1	Ground wire (1000mm)
B5		1	Battery to inverter power Cable (red) (2000mm)
B6		1	Battery to inverter power Cable (black) (2000mm)
B7		1	Communication Cable (1400mm)

C. AW7500-ST Stack

No.	Item	Q'ty (pcs)	Note
C1		1	Base
C2		1	Wall mount angle bracket
C3		1	M8 x 80mm Expansion bolt
C4		1	Ground wire (1000mm).
C5		1	Battery to inverter power cable (red) (1500mm)
C6		1	Battery to inverter power Cable (black) (2000mm)
C7		1	Communication Cable (2000mm)
C8		1	M6 x 8mm screw
C9		1	RJ45 header

3.2 INSTALLATION ENVIRONMENT

3.2.1 ENVIRONMENTAL REQUIREMENTS

- **Temperature:**
 - Operating: Charging: -10°C to +50°C; Discharging: -20°C to +65°C.
 - Recommended for optimal life: Charging: 0°C to +50°C; Discharging: -20°C to +55°C.
 - Ideal ambient temperature: 15°C to 30°C.
- **Humidity:** 5% to 95% RH (non-condensing).
- **Altitude:** Maximum 4000m above sea level.
- **Ventilation:** Ensure adequate airflow around the battery to prevent overheating.
- **Installation Surface:** The installation surface (wall) must be flat, level, and able to support the weight of the battery.

3.2.2 INSTALLATION LOCATION PRECAUTIONS

This product is IP65-rated for indoor and outdoor use, providing protection against dust and moderate rain or water jets. For optimal performance and longevity, install in a shaded location to avoid direct sunlight (which can cause overheating) and under a cover or eaves to protect from heavy rain or flooding.

! CAUTION:

Improper installation location can reduce battery life and pose safety risks. Avoid:

- Direct sunlight exposure
- Near flammable or explosive materials or gases.
- On or near flammable wall/floor materials (unless appropriate fire-resistant backing is used).
- Areas prone to flooding.
- Excessive dust or corrosive environments.

3.2.3 INSTALLATION SPACING

NOTICE:

Adequate spacing is crucial for ventilation, maintenance access, and safety.

- Allow sufficient front clearance for operation and maintenance.

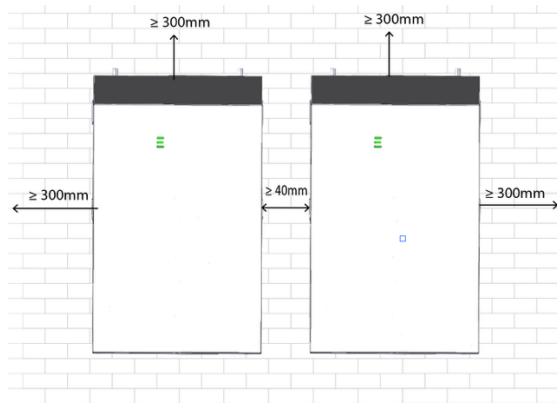

3.3 MECHANICAL INSTALLATION

! WARNING:

- The AW7500PRO unit weighs approximately 49.5kg. Use proper lifting techniques and assistance (e.g., two people or lifting aids) to prevent injury.
- Ensure the wall or mounting structure is strong enough to support the weight of the. Use appropriate anchors for the wall type.

3.3.1 MOUNTING THE BATTERY (WALL MOUNT)

Step 1: Mount Wall Bracket:

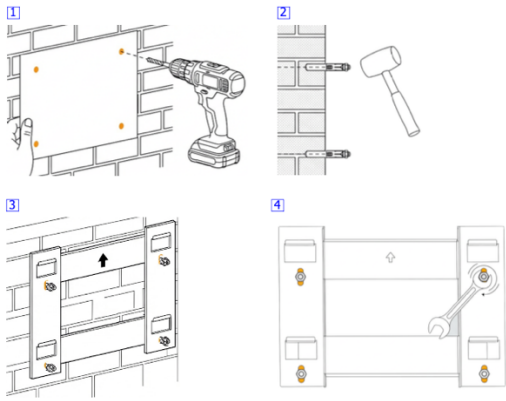

- Select a suitable wall location that meets all environmental and spacing requirements.
- Use a level to ensure Wall Bracket 1 is positioned correctly.
- Securely attach Wall Bracket 1 to the wall using the provided M10 x 80 expansion bolts (or other appropriate fasteners for your wall type). Ensure all fixing points are used and tightened to the correct torque.

Step 2: Attach Mounting Bracket to Battery:

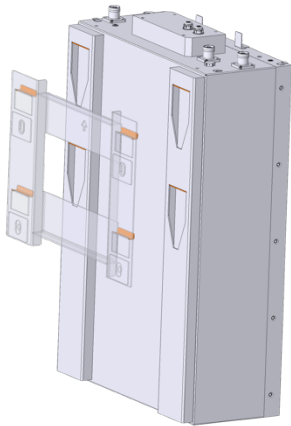

- Carefully place the AW7500PRO battery unit on a stable, protected surface.
- Align Mounting Bracket with the mounting holes on the rear of the battery.

Step 5: Unscrew Comms Terminal Cover to do electrical installation and commissioning.

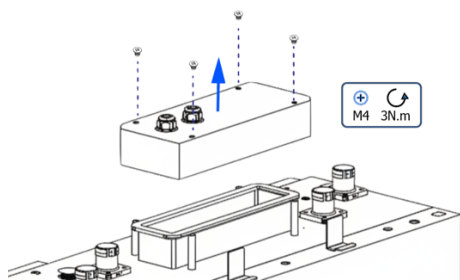

When finished all installation and commissioning, Attach and screw: Comms Terminal Cover. Tighten the screw to 3 Nm.

Final step : Attach Top Cover:

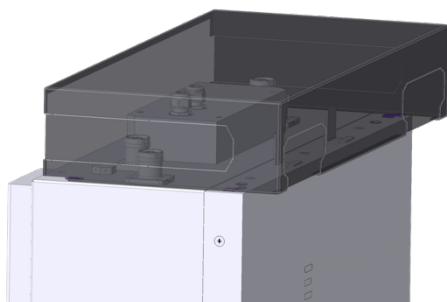

- After installation and commissioning, place the top cover on the battery

! CAUTION:

Do not unscrew the front cover - Only unscrew and demount the wall bracket, top cover, and Comms Terminal Cover on the top of the battery unit as necessary for safe removal. Do not attempt to unscrew or remove any other screws, components, or covers (e.g., front cover, internal panels, or battery terminals) to avoid risk of electric shock, equipment damage, or voiding the warranty.

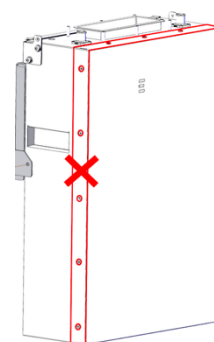

3.3.2 AW7500PRO-ST (STACKING UP TO 6 AW7500PRO BATTERIES)

- Installation surface must be flat, solid, and capable of supporting the total stack weight (~300kg for 6 units).
- Ensure the casing is dry and clean.
- **WARNING:** Do not install outdoors during precipitation (rain/snow).

Step 1: Base Installation

Place the base on the designated location. Adjust the leveling feet until the base is perfectly level (Figure 1).

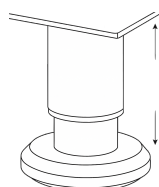
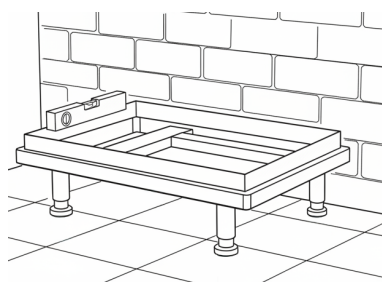
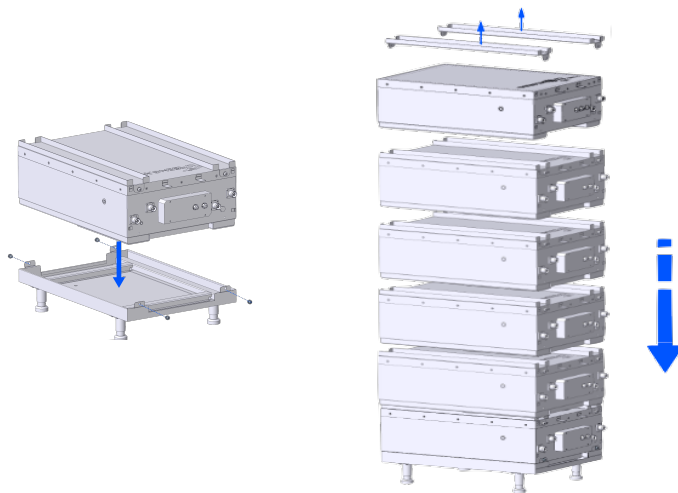

Figure 1 Leg height can be adjusted

Step 2: Stacking Battery Modules

1. Seat the first module onto the base. Align the corners and tighten the locking screws (C8).
2. Stack subsequent modules (up to 6 total).

3. **Note:** Remove the mounting rack brackets from the top-most battery module to prepare for the top cover.



Step 3: Wall Anchoring (Anti-Tip)

Critical Safety Step: To prevent tipping, mount the wall anchor brackets (C2) to the wall using expansion bolts (C3) and secure them to the battery stack using screws (C8).

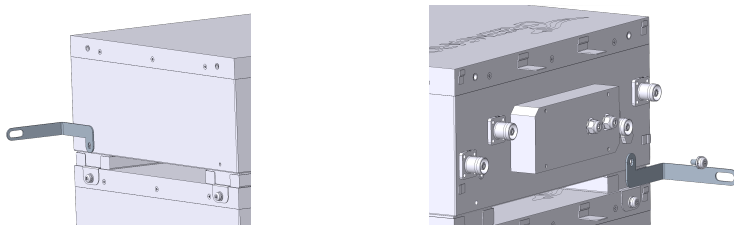

3.4 ELECTRICAL INSTALLATION

⚠ DANGER

- **Verify De-energization:** Before making any connections, use a multimeter to confirm that all power sources (grid, PV, other batteries, inverter) are completely OFF and locked out. Verify that there is no voltage present on any conductors or terminals you will be working with.
- **Correct Polarity:** Double-check all connections for correct polarity. Reversed polarity can cause severe damage to the battery, busbars, inverter, and other equipment, and may create a fire or explosion hazard.
- **Proper Torque:** Tighten all terminal connections (battery plugs, OT ring terminals to busbars, busbar to inverter connections, ground terminals) to the manufacturer's recommended torque specifications using a calibrated torque wrench. Loose connections can cause overheating, arcing, and fire. Over-tightening can damage terminals or connectors.
- **Qualified Personnel:** All electrical installation work must be performed by qualified and certified electricians or personnel specifically trained in lithium battery energy storage systems.

NOTICE:

The cable specifications and connection methods described herein are for the AW7500PRO unit itself. The installer is responsible for correctly sizing, protecting, and installing all external cabling (e.g., from busbars to inverter) and circuit protection devices according to the total system current, voltage drop considerations, and all relevant electrical codes.

! WARNING

- **Short Circuits:** Always prevent short circuits. Do not allow tools or any conductive material to bridge positive and negative terminals or live parts. Use insulated tools.
- **Battery Plugs:** Handle battery plug connectors with care. Ensure they are correctly oriented and fully seated when making connections. Do not force connect the connectors.

3.4.1 GROUNDING

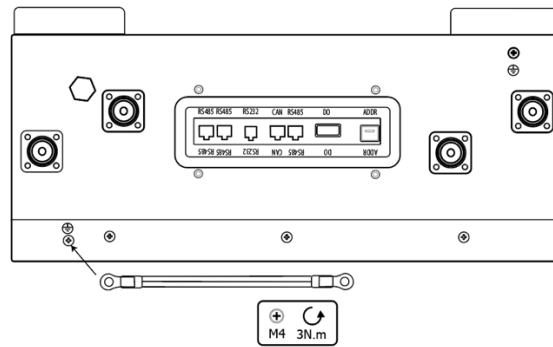

1. Identify the Ground Terminal (on each AW7500PRO battery unit).
2. Using the provided **Ground Wire**, connect one end to the Ground Terminal on the battery unit. Tighten the screw to 3 Nm.
3. Connect the other end of the Ground Wire to a dedicated system ground busbar or a verified common grounding point of the electrical installation.
4. Repeat for each battery unit in the system, ensuring each has an independent and reliable ground connection.
5. The system ground busbar must be properly connected to earth according to local electrical codes and standards.

NOTICE: Proper grounding is essential for safety, reducing electromagnetic interference (EMI), and ensuring correct operation of protective devices.

3.4.2 CABLE OVERVIEW AND PREPARATION

Installer-Supplied Cables:

- Cables from the main power busbars to the DC circuit breaker and then to the inverter must be sized appropriately by the installer based on the total system current, voltage drop considerations, and local electrical codes.

3.4.3 COMMUNICATION CABLE INSTALLATION

All communication cables (for inter-battery links or connection to the inverter) must pass through the Comms Terminal Cover to maintain the enclosure's integrity. Each battery is supplied with items for this purpose, including one **Communication Parallel Cable** (one pre-installed RJ45 plug, one bare-wire end), a spare **RJ45 Header**, and 2 **Waterproof Connectors**.



Step 1: Cable Gland Assembly

Pass the bare-wire end of the communication cable through the waterproof connector cap and housing.

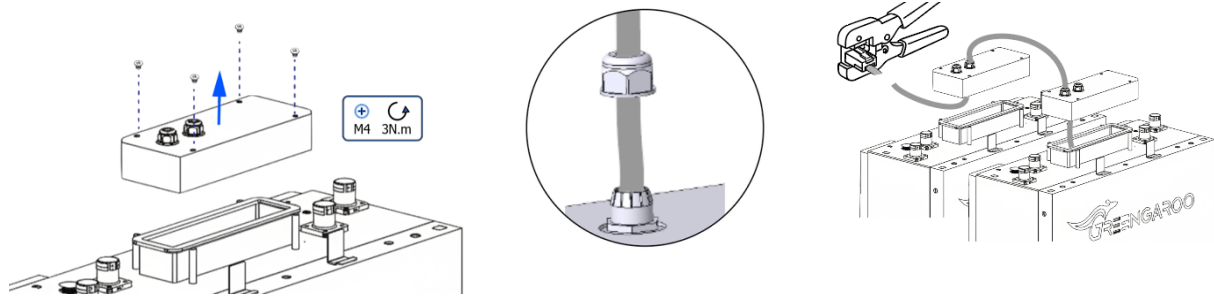

Unscrew the waterproof connector and thread bare-wire end of cable.

Step 2: Inter-Battery Connection (Daisy-Chain)

1. **Crimp:** Terminate the bare wire with the provided RJ45 header according to the pinout standard (Section 2.5.2).
2. **Connect:** Plug the cable into an available **RS485** port on the battery.
3. **Seal:** Tighten the waterproof connector to the port to maintain IP65 rating.
4. **Chain:** Connect the other end to the RS485 port of the next battery in the sequence (e.g., Master to Slave 1, Slave 1 to Slave 2).
5. **Terminating:** The last slave battery will have one empty RS485 port. Ensure this port is sealed with a cover plug.

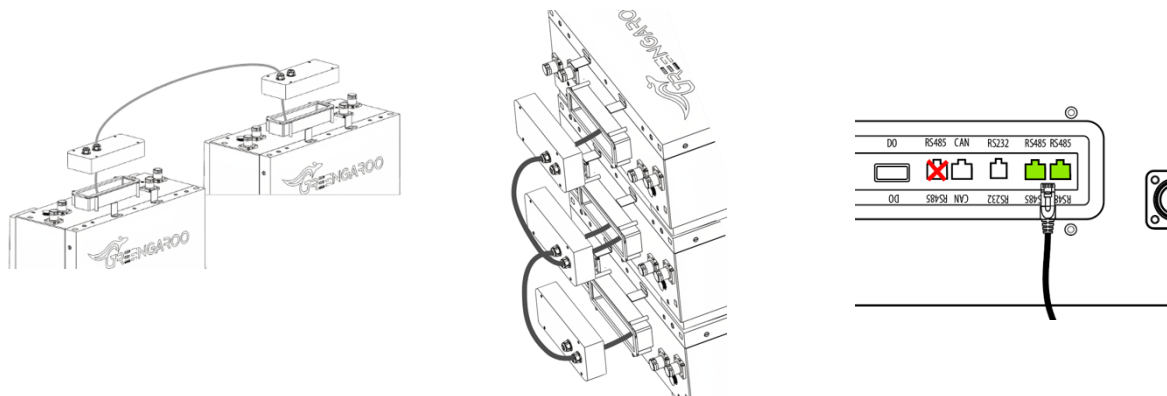

3.4.6 Master Battery to Inverter Communication

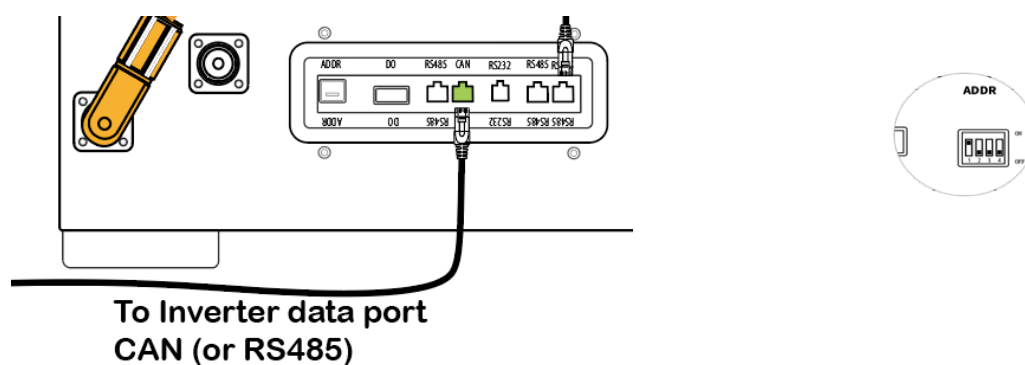

Only the designated Master Battery (Address 1) communicates with the inverter. Confirm DIP switch (ADDR) set to 1.

Note: Only the designated Master Battery (Address 1) connects to the inverter.

1. **Identify Protocol:** Determine if your inverter requires CAN or RS485 communication.
2. **Select Port:** On the Master Battery, locate the port labeled "**CAN / RS485**".
3. **Connection:** Connect the communication cable from the Master Battery to the inverter's BMS port.
4. **Pinout:** Ensure the cable pinout matches both the battery (Section 2.5.2) and the specific inverter model. Use a shielded CAT5e/6 cable to minimize interference.

NOTICE:

- Always run communication cables separately from high-current DC power cables to minimize electromagnetic interference (EMI).
- Configure the inverter with the correct battery communication protocol (e.g., CAN/RS485, baud rate) as specified by the inverter and battery documentation.

3.4.3 POWER WIRING

- Parallel batteries using orange (A2) and black (A3) cables.
- Connect orange (A5) from first battery to inverter/breaker positive.
- Connect black (A6) from last battery to inverter/breaker negative.



Figure 3 Wall mount

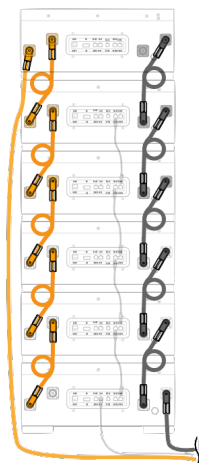
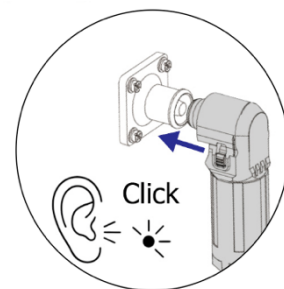

Figure 2 Stack



CAUTION:

- Ensure all positive cables connect only to the positive busbar and all negative cables connect only to the negative busbar.
- Keep cable runs neat and avoid excessive lengths. Secure cables to prevent strain on terminals.

3.4.4 CIRCUIT BREAKER INSTALLATION

NOTICE:

- An external DC circuit breaker is **mandatory** and must be installed between the main battery busbars and the inverter.
- **Selection Criteria:**
 - **Type:** Must be a DC-rated breaker.
 - **Voltage Rating:** Must be greater than the maximum possible system voltage (e.g., for a 51.2V nominal system that can charge up to ~57V, a breaker rated for at least 75V DC or higher is recommended).
 - **Current Rating:** Sized according to the maximum continuous charge/discharge current of the total battery system and the ampacity of the connecting cables. It should provide overcurrent protection for the cables and the inverter input. Consult inverter specifications and local codes.

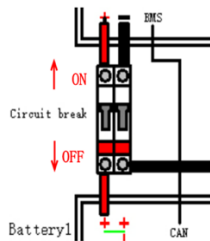

- **Interrupting Capacity:** Must be sufficient to safely interrupt the maximum potential fault current from the battery system.
- **Installation:**
 - Install the breaker in the positive line between the positive busbar and the inverter. Some installations may also require breaking the negative line.
 - The breaker must be installed in an easily accessible location for manual operation (ON/OFF) and emergency disconnection.
 - Follow the breaker manufacturer's installation instructions.

3.4.5 ADDRESS SETTINGS (DIP SWITCH)

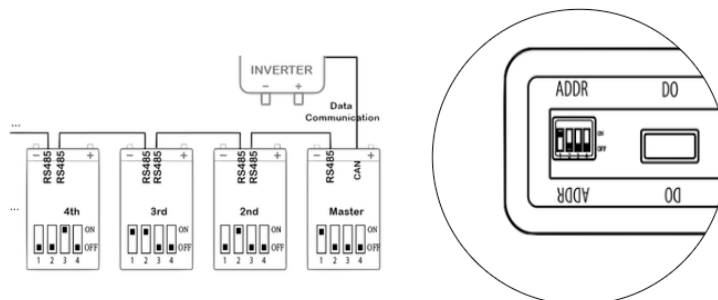

- Set the master battery (communicating with the inverter) to Address 1.
- Re-confirm that each battery in a parallel set has a unique address set via its ADDR DIP switch (Section 2.5.3).

3.5 SYSTEM CONFIGURATION

3.5.2 COMMUNICATION SETUP WITH INVERTER

- On the inverter, configure the battery type as "Lithium" or specifically "AW7500PRO" if listed.
- Select the correct communication protocol (CAN or RS485) and baud rate as required by the AW7500PRO and the inverter.
- Refer to both the AW7500PRO documentation (if more detail is provided on specific protocols) and the inverter manual for detailed setup instructions.

3.5.2 FINAL ASSEMBLY

Seal the Cover: Ensure all waterproof glands are tightened and unused ports are sealed with the provided plugs to maintain IP65 integrity.

- Tighten waterproof connector
- Re-install panel cover and front cover to battery modules
- Create openings for cables between batteries by removing the two knockouts on the side of the panel cover.

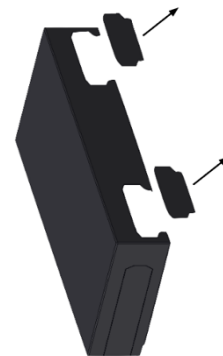
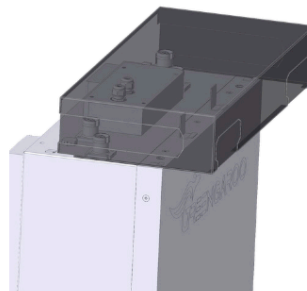
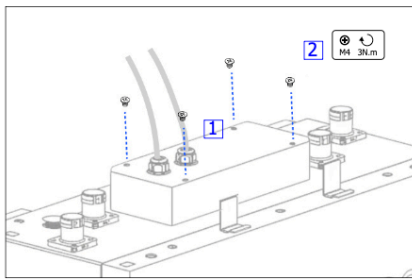

4. COMMISSIONING

⚠ WARNING:

- Commissioning involves energizing the system. Follow all safety precautions.
- If any abnormal conditions (sparks, smoke, unusual smells, error messages) are observed, immediately power down the system using the battery power switch and the external DC breaker and investigate the cause before proceeding.

4.1 PRE-POWER-ON CHECKLIST

Before powering on the system for the first time:

1. **Visual Inspection:** Double-check all mechanical installations are secure.
2. **Wiring Checks:**
 - Verify all power cable connections for correct polarity.
 - Confirm all power and grounding terminals are tightened to the specified torque.
 - Ensure all communication cables are correctly connected and secured.
3. **DIP Switch Settings:** Confirm correct and unique addresses for all parallel batteries. Master battery set to Address 1.

4. **External Breakers:** Ensure all external DC circuit breakers are in the OFF position. This includes the main external DC circuit breaker between the battery system and the inverter. For installations with multiple parallel batteries, this also includes the 2-pole isolation device installed on the output of each battery system.
5. **Inverter Status:** Ensure the inverter is initially OFF or in standby mode as per the inverter manual's first-time startup procedure.
6. **Environment:** Check that the installation environment meets requirements (temperature, humidity, no obstructions to ventilation).

4.2 INITIAL STARTUP PROCEDURE

4.2.1 POWERING ON THE BATTERY SYSTEM

1. **For each battery unit in the parallel system, starting with the Master (Address 1) and then slaves:**
2. **BMS Activation & Self-Test:**

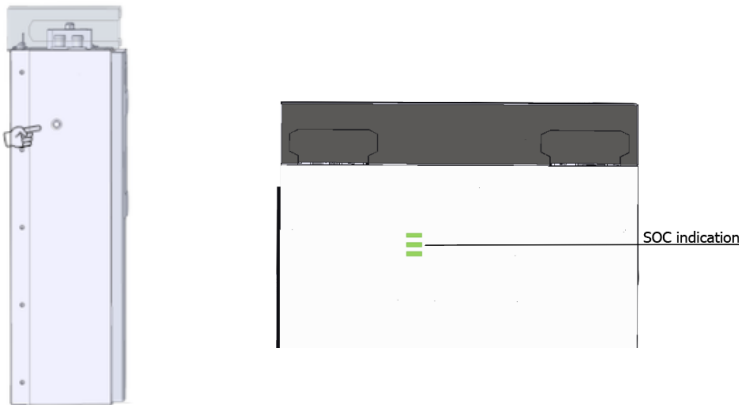

- Press the Power Switch (on the side of the battery to the "ON" position)
- Starting with the master battery (Address 1) for stack batteries, then activate the remaining modules sequentially
- Observe the LED indicators on the front panel.

4.2.2 VERIFYING LED INDICATORS

- After powering on, the SOC indicator should light up (e.g., solid green or flashing, refer to Section 5.2).
- The SOC (State of Charge) indicators should display the current charge level.
- Observe the SOC / Power Indicator LED Behavior & Color for any fault indications. Refer to Section 5.2 (LEDs). Do not proceed if a fault is indicated until it is resolved.

! WARNING:

If the SOC / Power Indicator LEDs indicate a fault, or if any abnormal behavior (e.g., unusual sounds, smoke, unusual smells, error messages) are observed, immediately power down the system using the battery power switch and the external DC breaker and investigate the cause before proceeding.

4.2.3 VOLTAGE CHECKS

1. **Individual Battery Voltages (Optional, for advanced check):** If accessible and safe, measure the voltage at the terminals of each battery unit to ensure they are within the expected range (e.g., 45V - 57V depending on SOC).
2. **System Output Voltage:**
 - With all batteries ON and the external DC breaker still OFF, use a multimeter to measure the DC voltage at the battery-side terminals of the external DC circuit breaker (or at the main output terminals of the master battery / busbar).
 - The voltage should be stable and within the AW7500PRO's operating range (e.g., approximately 52V-54V if shipped at 60-80% SOC, or corresponding to actual SOC).
 - Verify correct polarity.

4.3 INVERTER INTEGRATION AND SYSTEM TEST

1. **Power on Inverter:** Follow the inverter manufacturer's instructions to power on the inverter.
2. **Close External DC Breaker:** Once the battery system voltage and polarity are confirmed correct and the inverter is ready, switch the external DC circuit breaker (between battery and inverter) to the **ON** position.
3. **Verify Communication:**
 - Check the inverter's display panel or monitoring software for confirmation of communication with the battery BMS.
 - The inverter should recognize the battery and display its parameters (SOC, voltage, current).
 - If communication fails, re-check communication wiring, DIP switch settings, and inverter configuration (protocol, battery type).
4. **Functional Test:**
 - **Charging Test:** If a charging source (Grid/PV) is available and configured, initiate a system charge via the inverter. Monitor the charging current and voltage on the inverter and, if possible, via battery monitoring. Ensure they are within the AW7500PRO's specifications.
 - **Discharging Test:** Apply a load to the inverter. Monitor the discharging current and voltage. Ensure they are within specifications.
 - Observe the system for a period (Suggest at least 30 minutes) to ensure stable operation.

NOTICE:

If the battery system has been in storage for a long time, it may require a full charge cycle to calibrate the SOC estimation and balance the cells.

5. OPERATION

5.1 NORMAL OPERATION

Once commissioned, the AW7500PRO battery system will operate automatically, managed by its internal BMS and controlled by the connected inverter.

- The BMS will protect the battery from over-charge, over-discharge, over-current, and over/under-temperature conditions.
- The inverter will manage charging from sources like solar PV or the grid and discharging to supply loads.

5.2 LED INDICATOR STATUS

State	Normal/ Alarm/ Protection	SOC / Power Indicator LED Behavior & Color	Notes
Shutdown	Sleep	All SOC LEDs OFF	System is fully off or in deep sleep.
Standby	Normal	According to current SOC level (see "Discharge Normal" for colors)	Battery is ON, BMS active, ready. No charge/discharge.
Charge	Normal	SOC 0-25%: Red, Flashing SOC 26-50%: Yellow, Flashing SOC 51-75%: Blue, Flashing SOC 76-95%: Green, Flashing SOC 96-100%: Green, Solid	Flashing indicates charging in progress for that segment.
	OVP	ON	Switch to standby mode
	Temp/ occ/ failure	OFF	Stop Charging
Discharge	Normal	SOC 100-76%: Green, Solid SOC 75-51%: Blue, Solid SOC 50-26%: Yellow, Solid SOC 25-11%: Red, Solid SOC 10-0%: Red, Flashing	Solid color indicates the current SOC range. Flashing Red at very low SOC.
	UVP	OFF	Stop discharging
	Temp/ ocd/ ascd/ failure	OFF	Stop discharging

5.3 SHUTTING DOWN THE SYSTEM

For Maintenance or Emergency:

1. Turn OFF loads connected to the inverter.
2. Switch all external DC circuit breakers to the **OFF** position. This includes the main external DC circuit breaker between the battery system and the inverter. For installations with multiple parallel batteries, this also includes the 2-pole isolation device installed on the output of each battery system.
3. Turn OFF the charging source to the inverter (e.g., PV array isolator, grid input breaker to the inverter).
4. Press the Power Switch on each AW7500PRO battery unit to the "OFF" position, starting with slave units and then the master unit.

For Short Periods (System remains available):

- The inverter may have a standby or off mode that can be used. The battery itself will enter a low-power state if there's no charge/discharge activity.

6. MAINTENANCE

! WARNING:

- Maintenance should only be performed by qualified personnel.
- Always power down the battery system and disconnect it from the inverter (via the external DC breaker) before performing any physical maintenance unless otherwise specified for live checks.
- Wear appropriate PPE.

6.1 ROUTINE MAINTENANCE SCHEDULE

Check Content	Maintenance Method	Maintenance Cycle
System Cleaning	Check for dust, debris, or corrosion. Clean the exterior of the battery units with a dry or slightly damp (water only) lint-free cloth. Ensure ventilation openings are clear. Check for any physical damage or deformation.	Once every six months to once a year.
System Running State	Check for any abnormal sounds during operation (before shutdown for other checks). Check that LED indicators work normally during operation. Check system parameters (SOC, voltage, temperature) via inverter monitoring or BMS software (if accessible) are normal.	Once every six months.
Electrical Connections	Visually inspect all power and communication cable connections for tightness, signs of overheating (discoloration), corrosion, or damage. ! CAUTION: Torque checks should only be done by qualified personnel with the system powered down. Check cable insulation for damage, especially where cables contact metal surfaces or pass through openings.	Half a year after first commissioning, then once every half a year to a year thereafter.
Ground Reliability	Visually inspect the ground cable connection for tightness and corrosion.	Annually.
Ventilation	Ensure that ventilation pathways around the batteries and in the room are not obstructed.	Quarterly.

NOTICE:

Failure to perform routine maintenance as outlined, or performing maintenance with unqualified personnel, can lead to premature product degradation, system malfunction, safety hazards, and may void the product warranty.

6.2 CLEANING

- Use a soft, dry cloth to clean the exterior of the battery.
- If necessary, a cloth lightly dampened with clean water can be used.

! CAUTION:

Never use solvents, abrasive cleaners, or large amounts of water, as these can damage the casing or internal components. Ensure the unit is dry before re-energizing.

6.3 CABLE AND CONNECTION CHECKS

- Regularly inspect cables for any signs of wear, cracking, or damage to the insulation.
- Check terminals for any signs of corrosion or looseness. If corrosion is present, the connection should be cleaned and re-secured by qualified personnel. If looseness is suspected, terminals should be re-torqued to specification by qualified personnel with the system de-energized.

6.4 BATTERY HEALTH AND SOC MANAGEMENT

- Avoid frequently discharging the battery to very low SOC levels (e.g., below 10%) if not necessary, as this can impact long-term cycle life for some LiFePO₄ usage patterns.
- Ensure the battery undergoes a full charge cycle periodically (e.g., quarterly or as recommended by the inverter settings) to allow for cell balancing and SOC calibration.
- If the system is not used for extended periods, follow long-term storage guidelines (Section 7.2).

7. STORAGE

7.1 SHORT-TERM STORAGE (UP TO 3 MONTHS)

- Store the battery in a cool, dry, well-ventilated area.
- Storage Temperature: -20°C to +45°C.
- Relative Humidity: 5% to 85% RH.
- Ensure the battery's Power Switch is OFF.

- SOC should ideally be between 40% and 60%. If SOC is very low, charge it before storing.

7.2 LONG-TERM STORAGE (MORE THAN 3 MONTHS)

- **Storage Temperature:** -20°C to +25°C is optimal for minimizing capacity loss.
- **SOC:** Charge or discharge the battery to 60%~80% SOC before storage.
- **Recharge:** Recharge the battery to 60%~80% at least every six months. Failure to do so can lead to irreversible capacity loss or battery damage due to self-discharge.
- **Environment:** Store in a dry, clean, well-ventilated area away from corrosive substances, heat sources, and direct sunlight.
- **Power Switch:** Ensure the battery's Power Switch is OFF.

⚠ CAUTION:

Non-compliance with the specified storage conditions, including temperature, SOC, and periodic recharging, will significantly reduce the battery's lifespan, lead to irreversible capacity loss, and may void the warranty.

8. DECOMMISSIONING AND DISPOSAL

8.1 SAFE DECOMMISSIONING

1. Follow the shutdown procedure in Section 5.3 to safely power down the battery system and isolate it from the inverter and other power sources.
2. Disconnect all cables from the battery unit(s) by qualified personnel.
3. Carefully demount the battery unit(s) from the wall.

⚠ CAUTION:

Only unscrew and demount the wall bracket, top cover, and Comms Terminal Cover on the top of the battery unit as necessary for safe removal. Do not attempt to unscrew or remove any other screws, components, or covers (e.g., front cover, internal panels, or battery terminals) to avoid risk of electric shock, equipment damage, or voiding the warranty. There are no user-serviceable parts inside; contact authorized service personnel for any internal access.

8.2 BATTERY DISPOSAL

⚠ DANGER:

Improper disposal of lithium batteries can harm the environment and pose safety risks.

- **DO NOT** dispose of lithium batteries in household waste or landfills.
- **DO NOT** incinerate lithium batteries.
- AW7500PRO batteries must be recycled by an authorized battery recycling facility that handles LiFePO₄ chemistry.
- Contact your local waste management authorities, installer, or battery supplier for information on approved collection and recycling programs in your area.
- Follow all local and national environmental regulations for battery disposal.

9. APPENDIX

9.1 COMPATIBLE INVERTER LIST

Brand	Model
Solis	S6-EA1P3.6K-L, S6-EA1P4.6K-L, S6-EA1P5K-L, S6-EA1P6K-L
DEYE	SUN-3K-SG04LP1-AU, SUN-3.6K-SG04LP1-AU, SUN-5K-SG04LP1-AU, SUN-6K-SG04LP1-AU, SUN-7.6K-SG04LP1-AU
SUNGROW	SPA-3000TL-BL-UP, SPH-3000~6000TTL-BL-UP
SMA	SUNNY ISLAND 4.4M/6.0H/8.0H
Sunsynk	SUNSYNK-3.6K-SG03LP1-AU, SUNSYNK-5K-SG03LP1-AU
Lux Power	LXP3/3.6/4/4.6/5/6K

Warranty Claim Form

Note: Signature or Seal stamp required. Please print, sign or stamp and then email to the Distributor. Distributor shall have no obligation for unqualified application such as incorrect information or missing necessary information.

Product Model		Serial Number(S/N)	
Company Name			
Contact Person		Contact Number	
Contact Email			
Company Address			
Name of End user			
Date of Installation			
Installation Location (Outdoors and indoors)			

Fault Description

Can the battery start up	Communication is normal	LED status (Quantity and color)



Warranty Claim Authorized Signature:

The following information must provide after faulty battery been replaced Replacement Information

Replaced by		Replace Date	
-------------	--	--------------	--

Replacement Information Authorized signature:	
Contact Distributor:	
Distributor Name: (With stamp for confirmation)	
Contact Email:	
Telephone #:	

GNW POWER
GREEN A NEW WORLD

 www.gnwpower.com
 info@gnwpower.com
