

Slim Wall mounted residential energy storage system

# AF16000

## Installation Manual

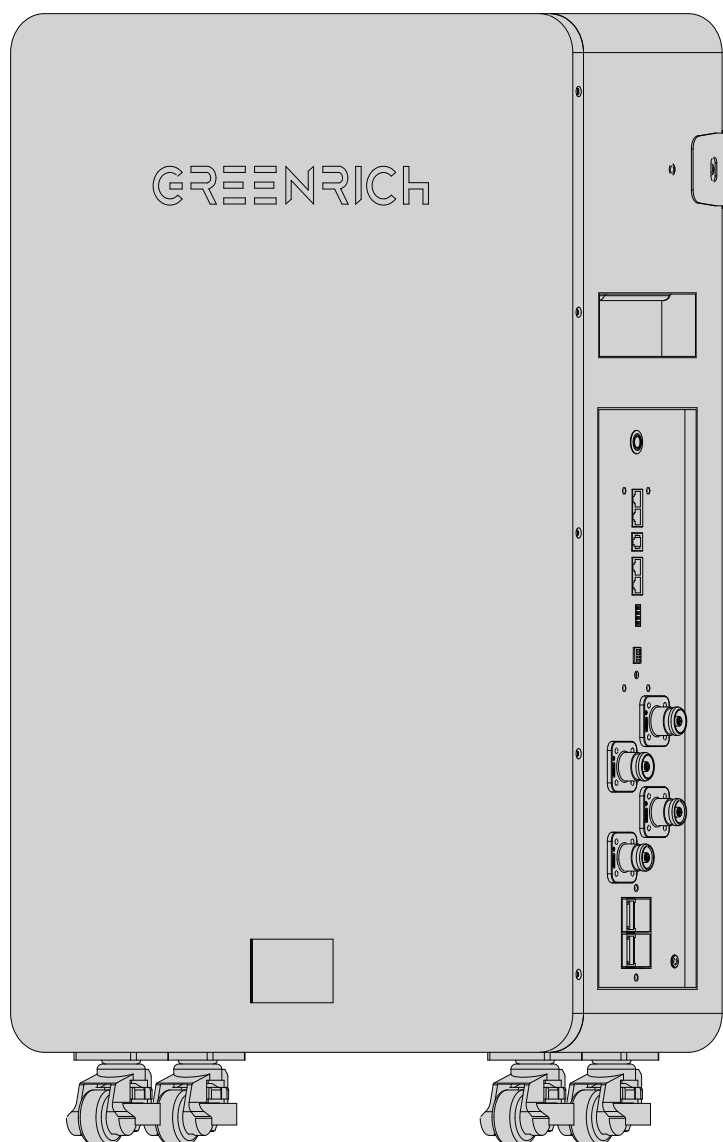

Document version 01  
Release date 2026-01-06

# Contents

<b>1.Basic information</b> .....	1
1.1 Introduction of energy storage function .....	1
1.2 Overall appearance of energy storage system .....	1
1.3 Deliverables .....	2
1.4 Battery pack size and parameters .....	3
<b>2.Installation of equipment</b> .....	4
2.1 Pre installation inspection .....	4
2.2 Installation methods .....	4
2.3 Installation requirements .....	5
2.4 Installation steps .....	6
<b>3.Electrical and communication connection of battery module</b> .....	7
3.1 Installation wiring and parallel outcome .....	7
3.2 Installation completion outcome .....	7
<b>4.Communication</b> .....	8
4.1 Description of communication terminal of battery expansion module .....	8
4.2 Energy storage system cable connection .....	8
<b>5.Inspection after installation</b> .....	9
<b>6.System maintenance</b> .....	10
<b>7.Statement</b> .....	11

---

# 1. Basic information

## 1.1 Introduction of energy storage function

This module is applicable for indoor use only. The battery module can store and release electric energy by connecting it to a compatible inverter management system according to the customers requirements.

**Battery charging :** The battery module is connected to the energy storage inverter via the amphenol connectors to charge the battery under the control of the inverter and store energy generated by the grid, photovoltaic, diesel generator, etc into the battery.

**Battery discharge :** When photovoltaic energy is insufficient or a loss of grid supply to the load occurs, the inverter system will control the battery supply to the load and output the battery energy, stored, to the load through the inverter.

## 1.2 Overall appearance of energy storage system

Figure1-1 overall appearance of energy storage system

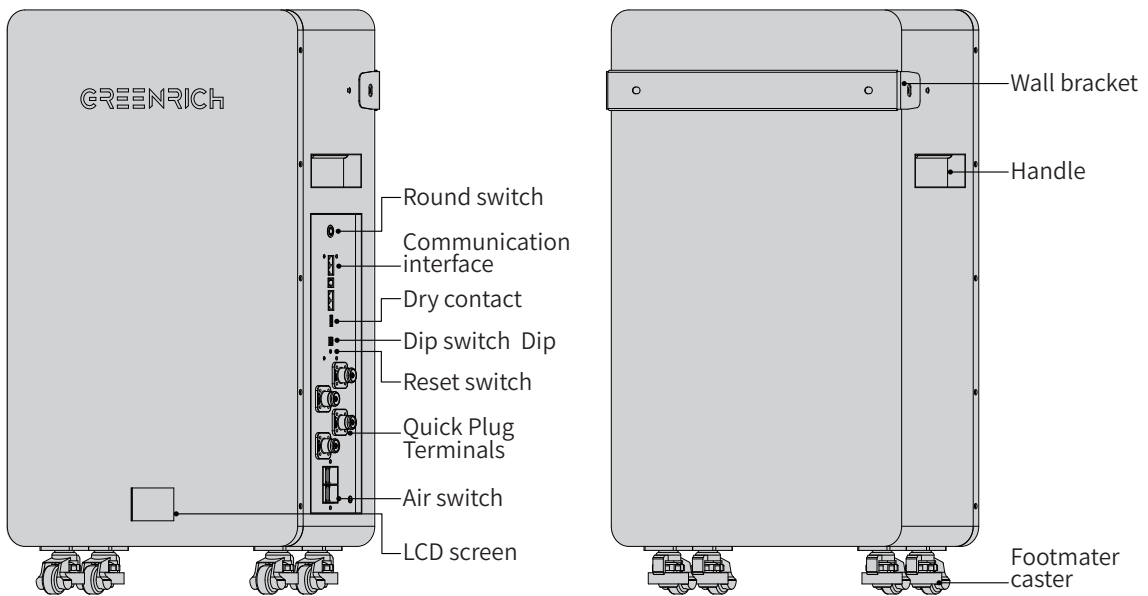

### 1.3 Deliverables

Name	Specifications	Number
B- negative power cable	1AWG L=1400mm Black	1 pcs
B+ Positive power cable	1AWG L=1400mm Orange	1 pcs
Series power cable	1AWG L=240mm Black	1 pcs
Series power cable	1AWG L=240mm Orange	1 pcs
Network cable	Parallel connection between batteries Blue	1 pcs
Communication cable	Upper computer cable Black	1 pcs
Hanging rack	Hanging rack	1 pcs
Fixed trestle	Fixed trestle	2 pcs
Screw	M6*12 mm	4 pcs
Hexagonal expansion screw	M8*50 mm	2 pcs
Dry contact	Dry contact	1 pcs
Desiccant	100g	1 pcs

### 1.4 Battery pack size and parameters

Dimensions in mm

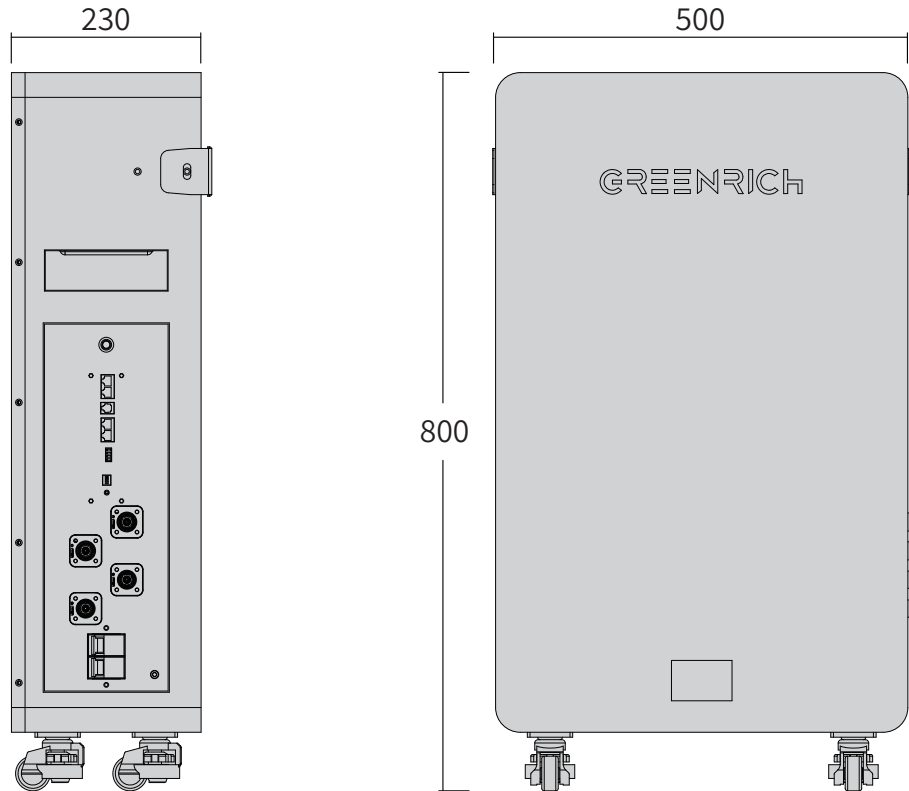

Parameters	
Battery Chemistry	LiFePO4@GF
Battery Configuration	16S1P
Nominal Voltage	51.2V
Total Capacity-optional	314Ah
Nominal Rating-optional	16kWh
Electrical Properties Parameters	
Operating Voltage Range	40-58.4V
Rated Charging Current	100A
Max. Charge Current	200A
Rated Discharge Current	100A
Max. Discharge Current	200A
Mechanical Parameters	
Net Weight	≈130kg
Dimension	800*500*230mm
Protection Rate	IP20
Communication Type	CAN/RS485
Operating Temperature Range	Charging: 0~55°C, Discharging: -20~55°C
Max. Parallel Connections	15 PCS

## 2. Installation of equipment

### 2.1 Pre installation inspection

- When unpacking the product, be sure to conduct appearance inspection. If the main body of the product is damaged, please consult the dealer and do not install the equipment.
- The appearance defects (such as scratches, friction, dents, etc.) of the product after installation are not within the scope of product warranty.

### 2.2 Installation methods

#### Installation angle requirements

- The battery modules support floor and wall mounting.
- Please ensure that the battery modules are installed upright or horizontally. Please do not install the modules upside down or on its face.

Figure2-1 Danger caution

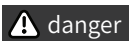

- When installing the battery, if the battery falls or is strongly impacted, it may cause internal damage to the equipment. It is strictly prohibited to continue to use it, otherwise there will be safety risks. (there may be leakage of electric core, electric shock injury, etc.)

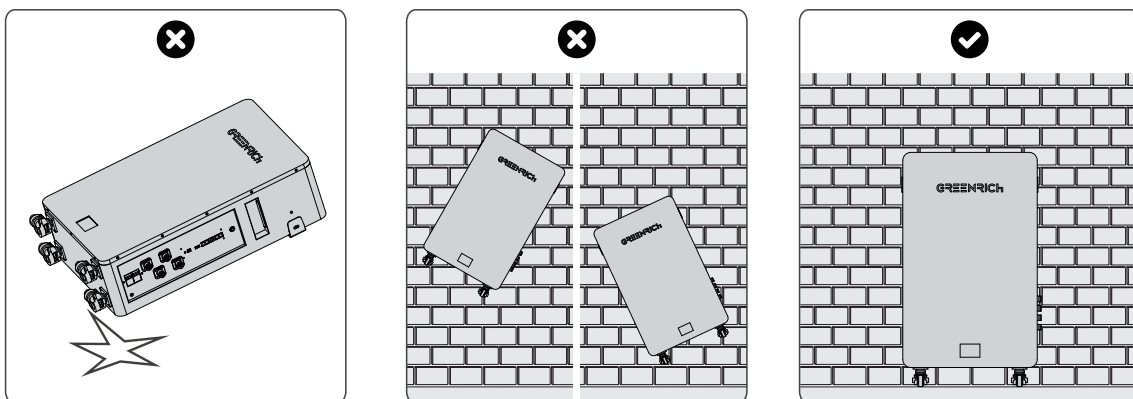

#### Installation position requirements

- Please make sure the battery modules are selected to be installed indoors, on a solid brick wall (Wall mount) or concrete floor (floor mount). If other types of walls or flooring is used, please make sure that they are flame retardant and meet the load bearing requirements.

Figure2-2 installation position

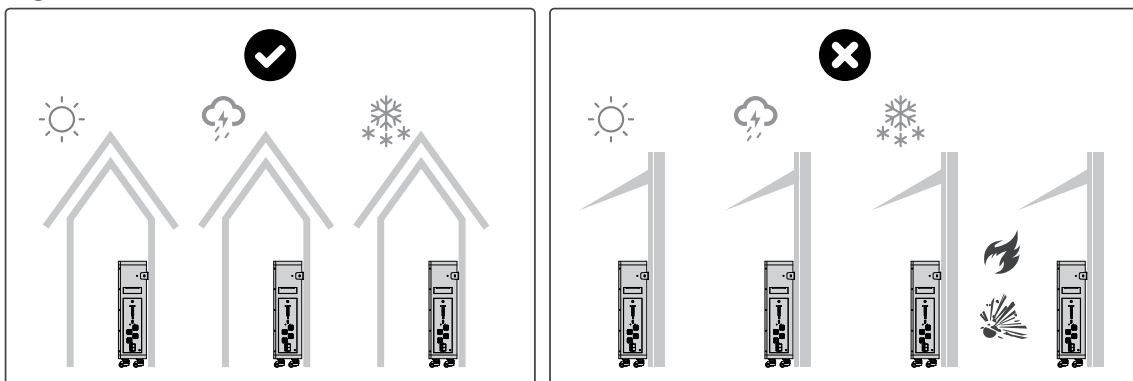
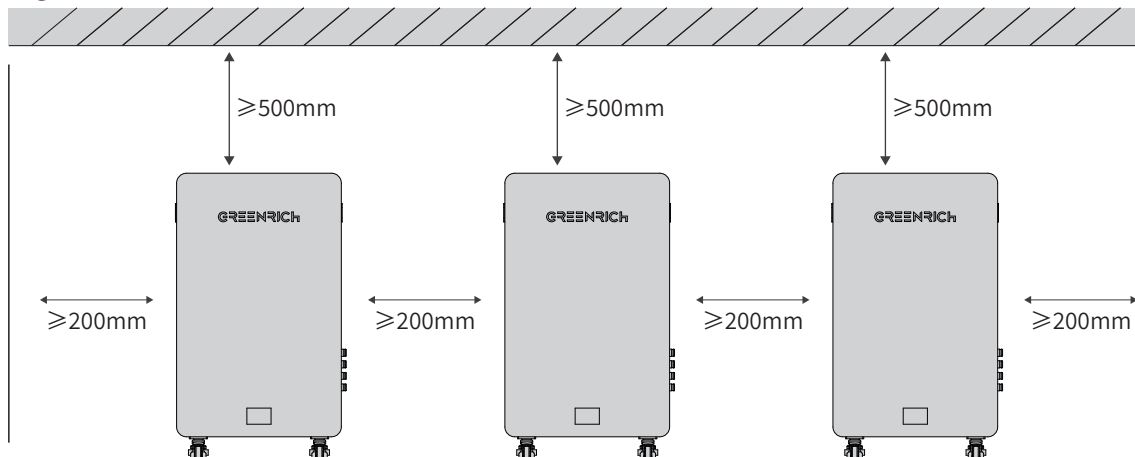

Figure2-3 installation space



## 2.3 Installation requirements

- The installation of lithium batteries should meet local laws and regulations.
- The installation location should not be accessible for children and must be kept far away from high-temperature and humid areas, including but not limited to the following areas: kitchen, sunlight room, bathroom, shower room, laundry room, attic.
- If installed in the garage, it is necessary to stay away from the direction of the vehicle to avoid accidents.
- If installed in a basement, you need to keep it ventilated. Do not place flammable and explosive items around the equipment. It is recommended to install a platform to avoid water accumulation.
- Install in dry, well ventilated environment, and fix the equipment on a sturdy and flat surface.
- The environment of the installation location should be clean, no significant infrared radiation, organic solvents and corrosive gases etc.
- In frequent occurrence of natural disasters such as floods, mudslides, earthquakes, and typhoons. Preventive measures are required for installation.
- The installation location should be far away from fire and heat sources. Do not place flammable and explosive items around the equipment.
- The installation location should avoid accumulated water, and keep away from water sources such as faucets, water pipes, sprinkler etc. to avoid water penetration.
- Don't place the equipment in an environment of flammable, explosive gases or smoke, and prohibit any operation in this environment.
- Don't install the equipment in mobile scenarios such as ships, trains and cars.
- When using a standby power source, do not use the power supply for the following scenarios.
  - a. For medical equipment directly related to human life.
  - b. Used for control equipment such as trains, elevators, etc., it may cause personal injury.
  - c. For computer systems with social and public significance.
  - d. Used for the location near medical equipment.
  - e. Used for similar devices as described above.
- Energy storage system will be corroded in salt damage areas. Do not install outdoor in the salt damage area. The salt damage area refers to the areas within 500m from the coast or are affected by the sea breeze. The area of the impact of sea breeze is different according to meteorological conditions (such as typhoon, seasonal wind) or terrain (dams, hills).

## 2.4 Installation steps against the wall

### Notice

- This step can select whether to install according to the actual needs.
- Install the anti tilt fixing bracket with the wall support and on the module using the M4 Screw provided with the box.

Figure2-4 fixing steps against the wall



- It is used for solid brick concrete structure walls. If you choose other types of installation walls, you can also choose the installation screws by yourself. Please ensure that it meets the requirement of 70kg for a heavy battery module.
- Before drilling, please make sure to avoid the water and electricity lines embedded in the wall to avoid danger.
- The installation position is far away from water sources such as faucets, sewer pipes, sprinklers and other places to avoid water infiltration.

### (Step 1)

Professional level measuring equipment shall be used by professionals for operation marking.

### (Step 2)

Please use the original M8 expansion screw to fix.

### (Step 3)

Place the product into the stand and fix it with screws.

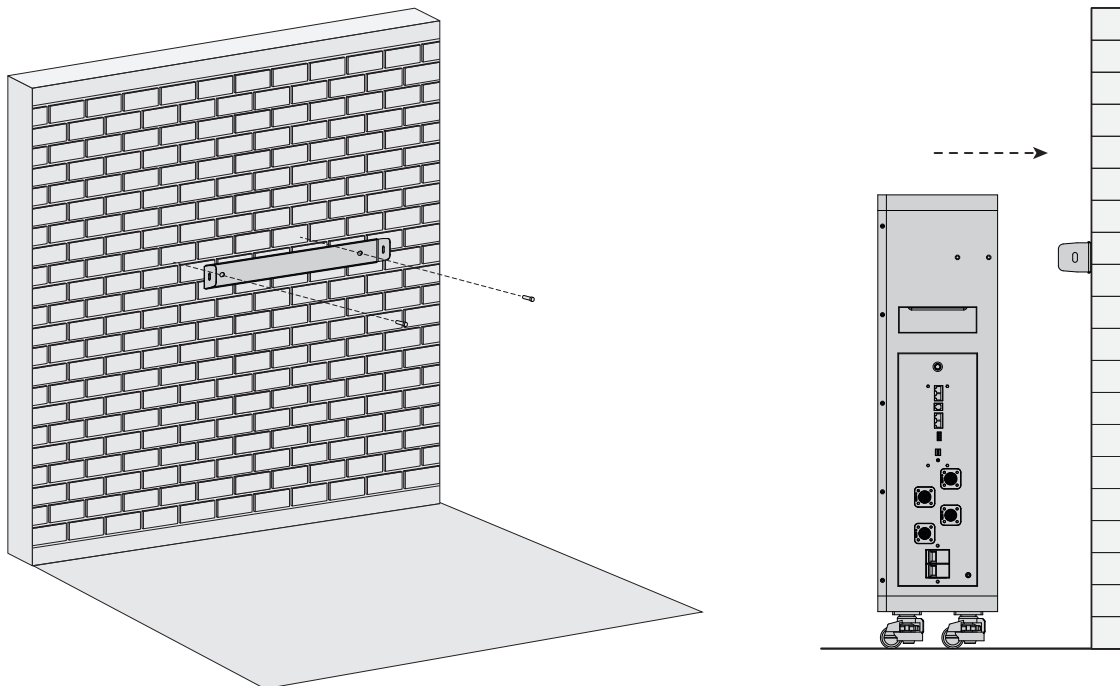



### 3. Electrical and communication connection of battery module

#### Matters needing attention

**⚠ danger**

- The electrical connection shall comply with the installation regulations of the country/region where the equipment is located.
- Before electrical connection, please ensure that the "power" of energy storage and all switches connected with energy storage are in the "off" state, otherwise the voltage of energy storage may cause electric shock hazard.
- Please confirm that the protective ground wire is reliably connected. If it is not connected or loose, it may cause electric shock.

**⚠ warning**

- Equipment damage caused by incorrect wiring is not within the scope of equipment warranty.
- The relevant operations of electrical connection must be carried out by professional electrical technicians.
- Operators must wear personal protective equipment when making electrical connections.

#### 3.1 Installation wiring and parallel outcome

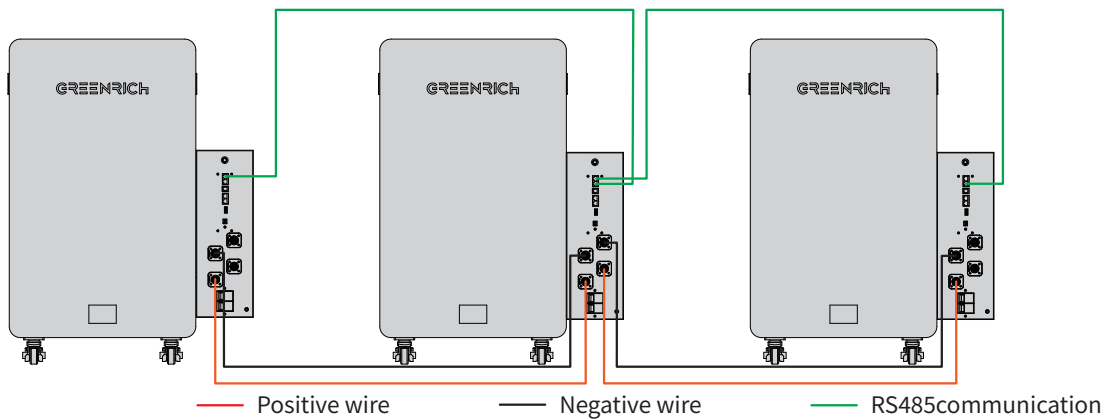

#### 3.2 Installation completion outcome

Notice

- After the installation of all electrical and communication lines, it is necessary to check whether the segment clips are fixed and whether the screws are fastened.

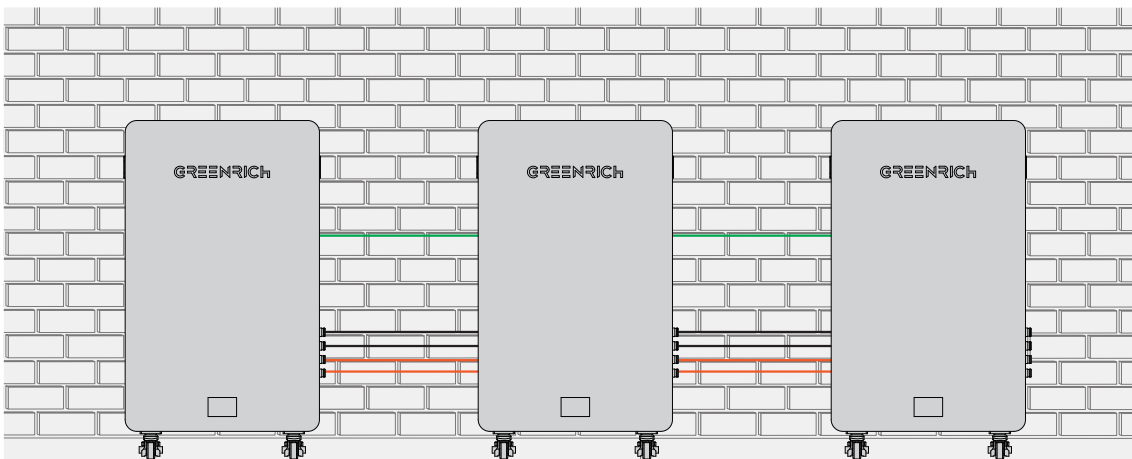

## 4. Communication

### 4.1 Description of communication terminal of battery expansion module

\*When Serial No. 2 (RS485B) and Serial No. 3 (CAN) ports are used, it is necessary to choose one from the other according to the communication type of the corresponding port of the current inverter.

Serial number	Label	Definition	Describe
1	PE	Shielding layer grounding	Shielding layer grounding
2	RS485B	Standard RJ45 port	Communication with inverter RS485 port
3	CAN	Standard RJ45 port	Communication with inverter can port
4	RS232	Standard RJ11 port	Communication debugging with PC upper computer
5	RS485A	Standard RJ45 port	Battery pack parallel communication port
6	RS485A	Standard RJ45 port	Battery pack parallel communication port

- It has RS interface for communication with upper computer.
- It has RS485A interface for parallel communication within BMS group, which can carry out multi machine parallel communication.
- RS485B/CAN interface for communication with inverter or terminal.

### 4.2 Energy storage system cable connection

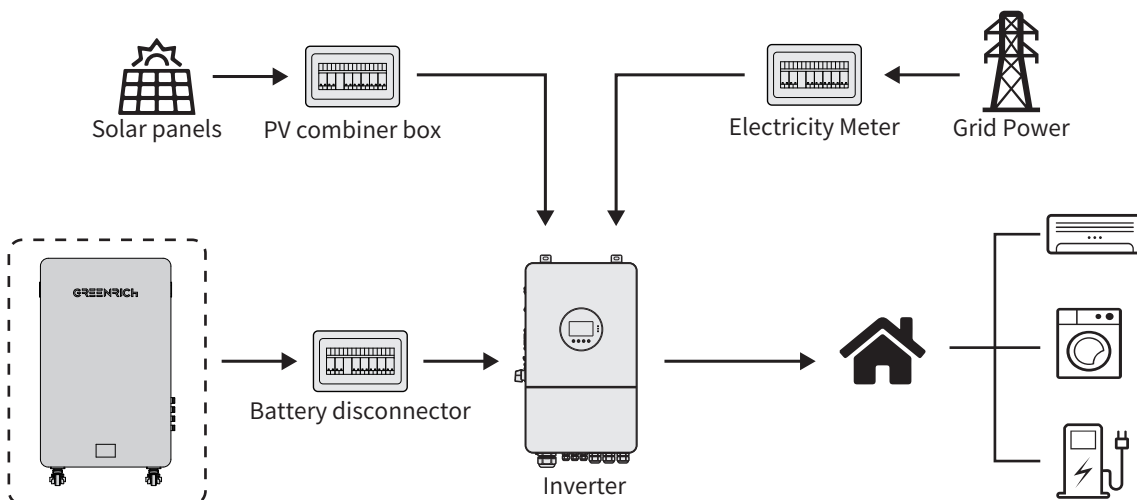

## 5. Inspection after installation

Task	Criteria
1	Please make sure the Battery modules are installed according to the wiring diagram.
2	Please make sure the cables are all sized correctly.
3	Please make sure all cable ties are cut correctly with no sharp edges.
4	Make sure the ground wire is connected firmly.
5	The switch and all switches connected to the energy storage are in the "off" state.
6	The DC input cable and communication cable are connected correctly and firmly.
7	The installation space is reasonable, the environment is clean and tidy, and there is no construction residue.

## 6. System maintenance

- ▶ In order to maintain the best long-term performance, the following items are recommended to be inspected twice a year.
  1. Confirm that the air flow around the system are not blocked, and remove any dirt or debris from the case of the battery.
  2. Check whether the insulation of all exposed wires is not damaged due to sunlight, friction with other surrounding objects, aging, insect or mouse damage, etc. Repair or replace the wires if necessary.
  3. Verify that the indication and display are consistent with the equipment operation. Please pay attention to any fault or error display and take corrective measures if necessary.
  4. Check all terminals for signs of corrosion, insulation damage, high temperature or burning/discoloration, and tighten the terminal screws.
  5. Check whether there is dirt, nesting insects and corrosion, and clean it as required.
  6. If the arrester has failed, replace the failed arrester in time to prevent lightning damage to the system and even other user equipment.

Warning: electric shock hazard! When carrying out the above operations, make sure that all power supplies of the system have been disconnected, and the capacitance has been discharged, and then carry out the corresponding inspection or operation!

- ▶ The company shall not be liable for any damage caused by the following circumstances:
  - Damage caused by improper use or use in inappropriate places.
  - The open circuit voltage of photovoltaic module exceeds the maximum allowable voltage.
  - Damage caused by the working environment temperature exceeding the limited working temperature range.
  - Disassemble and repair the system without permission.
  - Damage caused by force majeure: damage occurred during transportation or loading and unloading of the system.

## 7. Statement

1. Due to product version upgrade or other reasons, the contents of this document will be updated from time to time. Unless otherwise agreed, this document is only used as a guide, and all statements, information and suggestions in the document do not constitute any express or implied warranty.
2. Please read the "Installation Manual" carefully before installing the equipment to understand the product information and safety precautions.
3. All installation operations of the equipment must be carried out by professionally trained electrical technicians. Relevant personnel must wear personal protective equipment and use safe and reliable installation tools.
4. Before installing the equipment, please check whether the delivered parts are complete and free of any obvious external damage according to the packing list. If any items are missing or damaged, please contact your dealer.
5. After installation, please follow the instructions in this guide to ensure the correct use of this product. Equipment damage caused by failure to operate in accordance with the document is not within the scope of equipment warranty.
6. The cable colors involved in this article are for reference only, and the selection of cables should comply with local cable standards.
7. After reading, please keep the "Installation Manual" properly for future reference.
8. If you do not operate this product correctly, you may cause serious injury to yourself or others, or cause product damage and property loss.
9. Once you use this product, you are deemed to have understood, approved and accepted all the terms and contents of this document. Users promise to be responsible for their actions and all consequences arising therefrom. The company will not bear all losses caused by users' failure to use the product in accordance with the "Installation Manual".
10. In compliance with laws and regulations, the company has the final right to interpret this document and all related documents of this product.

